



BLF-FC, ALF-F

AUTO-LIFT FRYERS



BLF-FC

Optional microprocessor offers advanced control technology that enhances cooking capabilities



ALF-F

Patented "Quick-Disconnect" filter assembly ensures proper filter alignment

Easily implement and manage your fried food program with BKI's Auto-Lift Fryers. Load the food, set the fryer with the temperature control or optional microprocessor control and within minutes, a basket full of juicy, delicious food automatically rises and is ready to be served. BKI's patented "Quick-Disconnect" filtration system helps ensure a simple and easy filter assembly removal process.

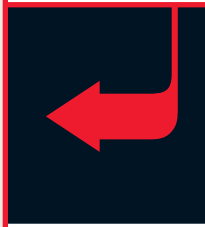

ALF-F

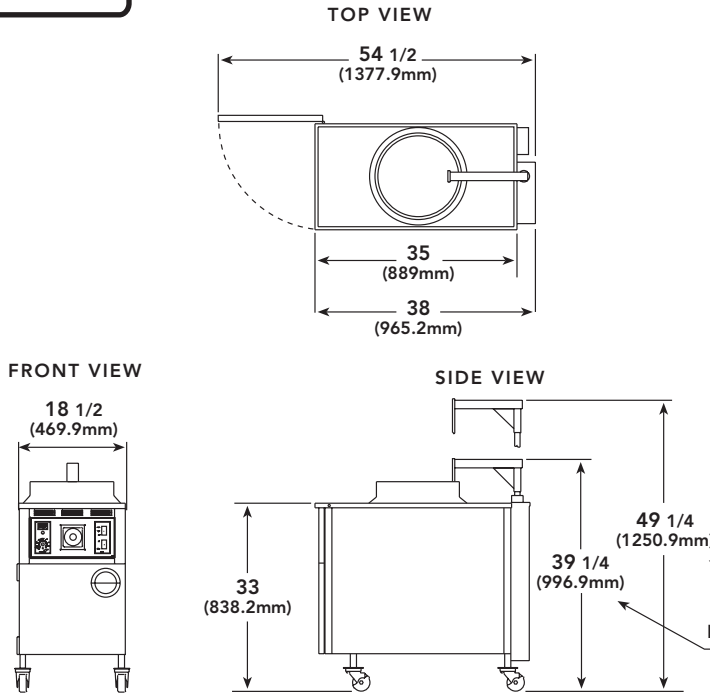

ELECTRICAL SPECIFICATIONS

Voltage	208	240
Phase	3 or 1	3 or 1
Wires	3 or 2	3 or 2
Amps	38 or 65	33 or 57
Breaker	50 or 70	50 or 70
kW	13.5	13.5

DIMENSIONS

Height	33" (838.2 mm)
Width	18 1/2" (469.9 mm)
Depth	38" (965.2 mm)
Floor Space	4.8 sq.ft (.45 m ²)
Shipping Weight	300 lb. (136.1 kg)
Shipping Cube	24.2 cu.ft (.68 m ³)

BLF-FC

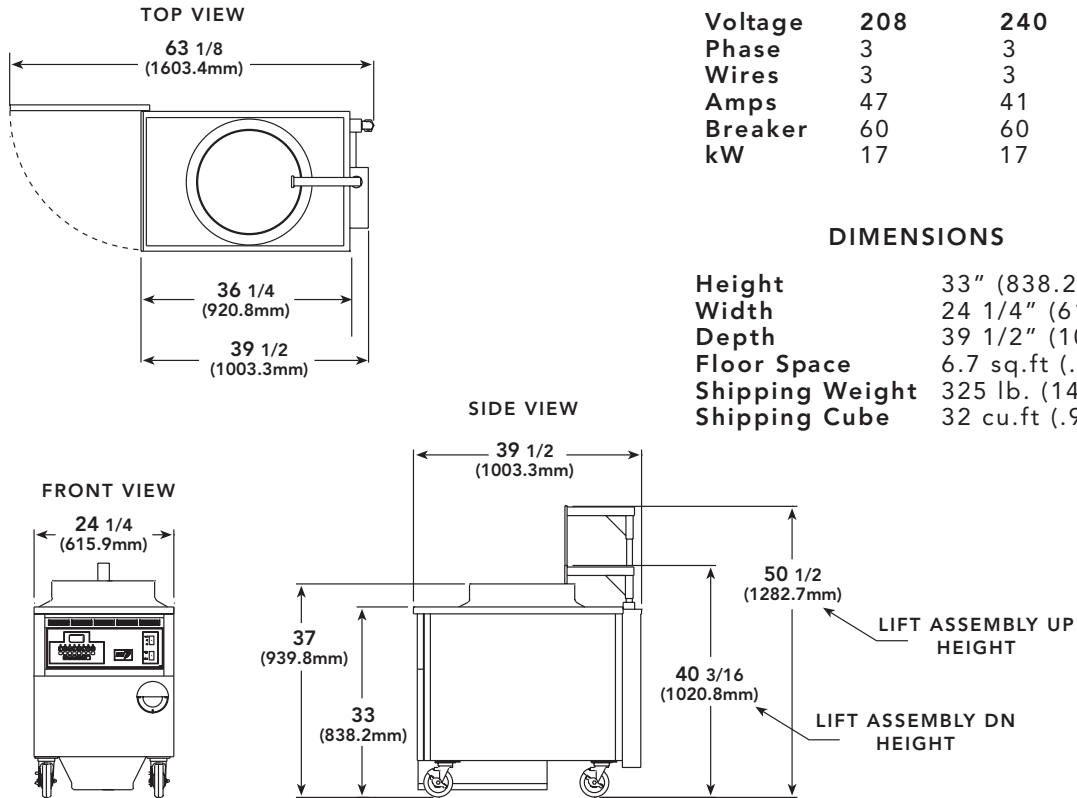

ELECTRICAL SPECIFICATIONS

Voltage	208	240
Phase	3	3
Wires	3	3
Amps	47	41
Breaker	60	60
kW	17	17

DIMENSIONS

Height	33" (838.2 mm)
Width	24 1/4" (615.9 mm)
Depth	39 1/2" (1003.3 mm)
Floor Space	6.7 sq.ft (.62 m ²)
Shipping Weight	325 lb. (147.4 kg)
Shipping Cube	32 cu.ft (.9 m ³)



BKI Worldwide Headquarters

P.O. Box 80400 Simpsonville, SC 29680-0400 USA • Tel: 864-963-3471 • Toll Free: 1-800-927-6887
 Sales Fax: 509-352-5350

BKI Europe (U.K.)

Tel: (44) 8950 8222
 Fax: (44) 8956 0233

BKI Latin America

Tel: 954-442-0480
 Fax: 954-442-0480

