



BHI-5T

## TIERED ISLAND HOT CASE



Expand presentation space with a two-tiered display surface

Thermostatically-controlled 'wedges' afford independent zoning for a wide variety of packaged and prepared foods

With BKI's self-serve tiered island hot case, hold a variety of items at varying temperatures for optimal product integrity and appeal. Vividly display prepared and packaged entrees and side items to stimulate customer interest and increase impulse sales. Built to hold constant and proper temperature, each individual 'wedge' has independent zoning so you can offer unlimited menu options to your customers.

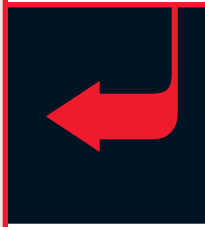

**BHI-5T**

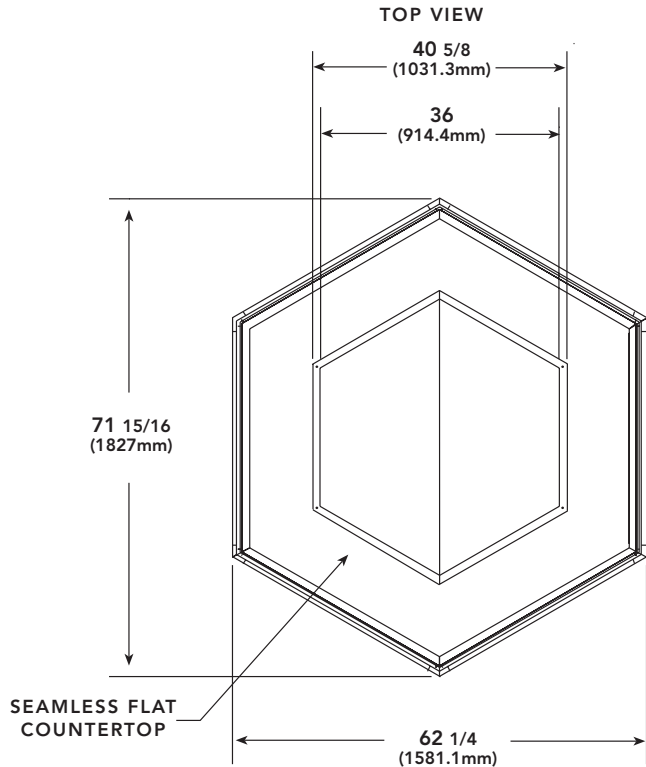

**ELECTRICAL SPECIFICATIONS**

<b>Voltage</b>	<b>208</b>	<b>240</b>
<b>Phase</b>	1/3	1/3
<b>Wires</b>	3/4	3/4
<b>Amps</b>	54.8/37.5	47.5/32.5
<b>Breaker</b>	70/50	60/40
<b>kW</b>	11.4	11.4

**DIMENSIONS**

<b>Height</b>	55 1/4" (1403.3 mm)
<b>Width</b>	71 15/16" (1827 mm)
<b>Depth</b>	62 1/4" (1581.15 mm)
<b>Floor Space</b>	31.125 sq.ft (2.89 m <sup>2</sup> )
<b>Shipping Weight</b>	985 lb. (447 kg)
<b>Shipping Cube</b>	257 cu.ft (7.3 m <sup>3</sup> )

NOTE: UNIT HAS FLAT SEAMLESS COUNTERTOP WITH LIGHTING UNDER MIDDLE SHELF AND TOP CANOPY

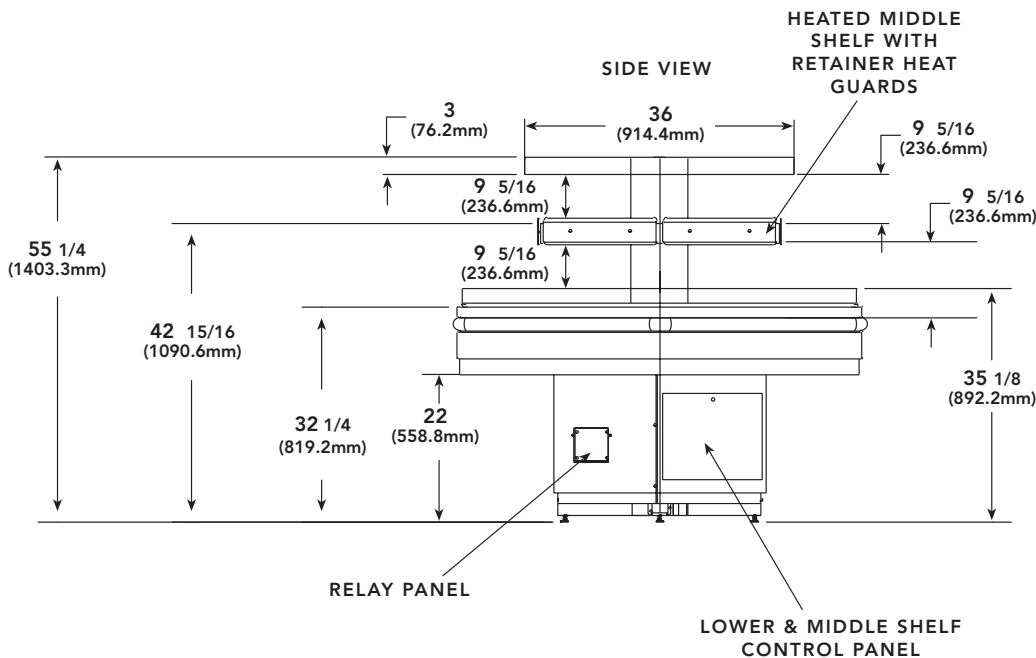

**BKI Worldwide Headquarters**

P.O. Box 80400 Simpsonville, SC 29680-0400 USA • Tel: 864-963-3471 • Toll Free: 1-800-927-6887  
Sales Fax: 509-352-5350

**BKI Europe (U.K.)**  
Tel: (44) 8950 8222  
Fax: (44) 8956 0233

**BKI Latin America**  
Tel: 954-442-0480  
Fax: 954-442-0480



Specifications subject to change without notice.  
© BKI LI0038/12-01