



DRCTSW-4

## ROTISSERIE/DELI CASE

Self-serve warmer displays enticing food at accurate and consistent temperatures to help reduce shrinkage



Double rotation ensures even, golden brown cooking and holds product for extended merchandising hours

Optional ceramic tiles enhance merchandising appearance and appeal

Increase sales volume and profit margin with BKI's double revolving oven and compact hot case that promotes total food visibility. The super-efficient production center fully maximizes floor space and merchandising capabilities for tender, self-basted food with a unique double-revolving mechanism for "show and sell" excitement.



**DRCTSW-4**

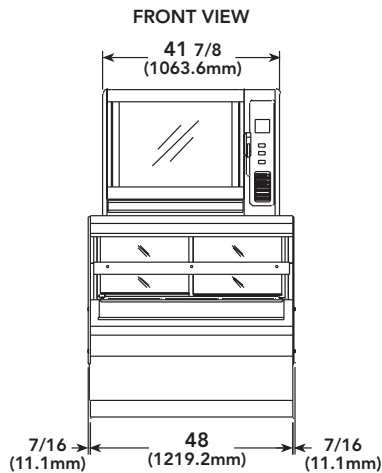

**DELI CASE ELECTRICAL SPECIFICATIONS**

Voltage	208	220	240
Phase	3/1	3/1	3/1
Wires	3/2	3/2	3/2
Amps	16.0/23.8	13.4/19.7	14.4/21.2
Breaker	20/30	20/30	20/30
kW	5.0	4.3	6.1

**ROTISSERIE ELECTRICAL SPECIFICATIONS**

Voltage	208	220	240
Phase	3/1	3/1	3/1
Wires	3/2	3/2	3/2
Amps	20.0/31.6	22.4/33.4	17.3/27.4
Breaker	25/35	30/40	20/30
kW	6.6	7.4	6.6

**DIMENSIONS**

Height	77 11/16" (1973.3 mm)
Length	48 7/8" (1241.4 mm)
Depth	38 3/8" (974.7 mm)
Floor Space	13 sq.ft (1.2 m <sup>2</sup> )
Shipping Weight	950 lb. (430.9 kg)
Shipping Cube	134.9 cu.ft (3.8 m <sup>3</sup> )

**DRCTSW-4P**

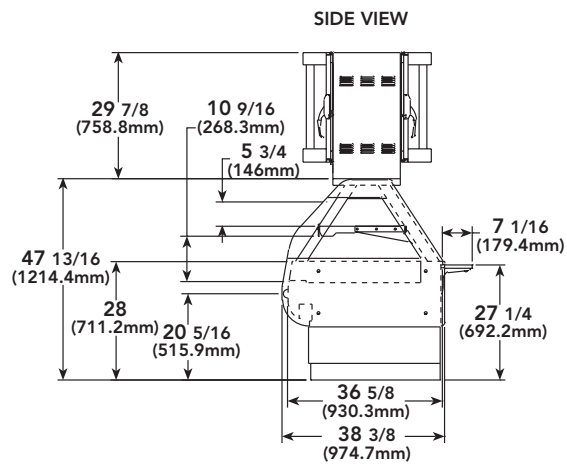
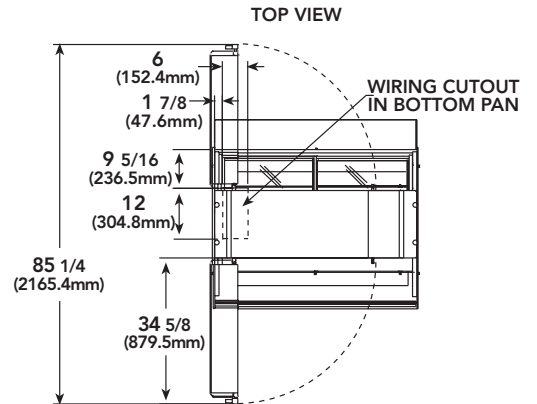
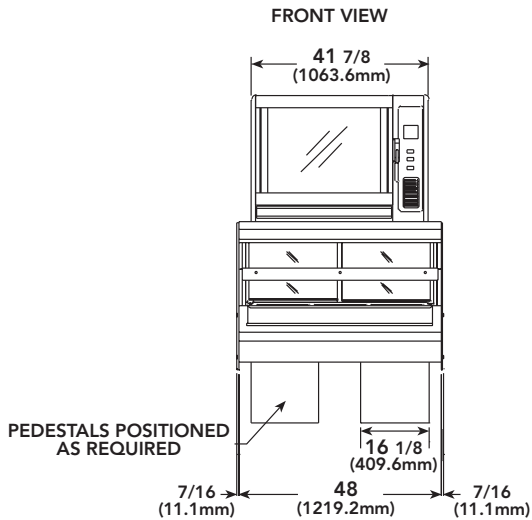

CASES HAVE VERTICAL ADJUSTMENT OF +1 1/2" (38.1mm)



**BKI Worldwide Headquarters**

P.O. Box 80400 Simpsonville, SC 29680-0400 USA • Tel: 864-963-3471 • Toll Free: 1-800-927-6887  
Sales Fax: 509-352-5350

**BKI Europe (U.K.)**

Tel: (44) 8950 8222  
Fax: (44) 8956 0233

**BKI Latin America**

Tel: 954-442-0480  
Fax: 954-442-0480



**SANITATION**

**DRCTSW-6**

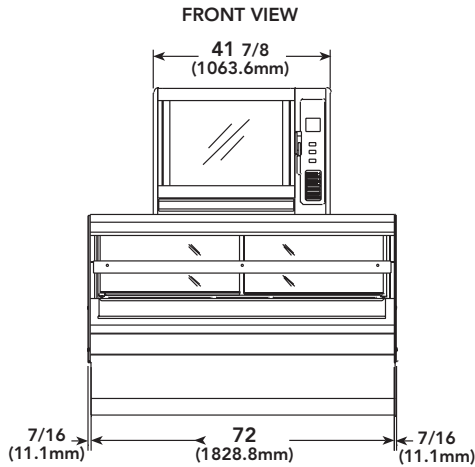

**DELI CASE ELECTRICAL SPECIFICATIONS**

Voltage	208	220	240
Phase	3/1	3/1	3/1
Wires	3/2	3/2	3/2
Amps	25.3/39.3	21.3/32.6	22.8/35.0
Breaker	35/50	30/45	30/45
kW	8.2	7.2	8.4

**ROTISSERIE ELECTRICAL SPECIFICATIONS**

Voltage	208	220	240
Phase	3/1	3/1	3/1
Wires	3/2	3/2	3/2
Amps	20.0/31.6	22.4/33.4	17.3/27.4
Breaker	25/35	30/40	20/30
kW	6.6	7.4	6.6

**DIMENSIONS**

Height	77 11/16" (1973.3 mm)
Length	72 7/8" (1851 mm)
Depth	38 3/8" (974.7 mm)
Floor Space	19.4 sq.ft (1.8 m <sup>2</sup> )
Shipping Weight	1090 lb. (494.4 kg)
Shipping Cube	192.14 cu.ft (5.4 m <sup>3</sup> )

**DRCTSW-6P**

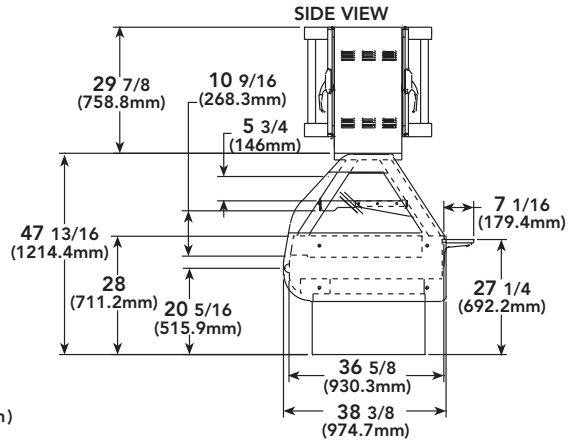
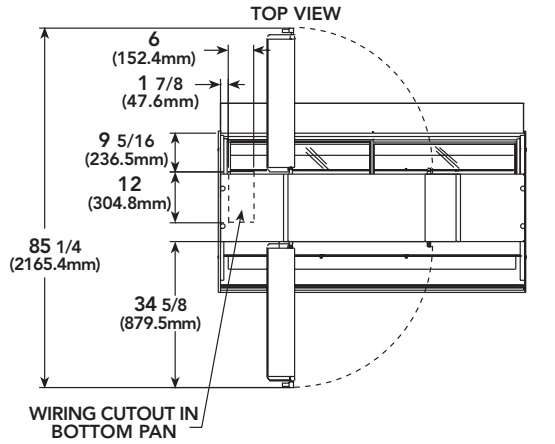
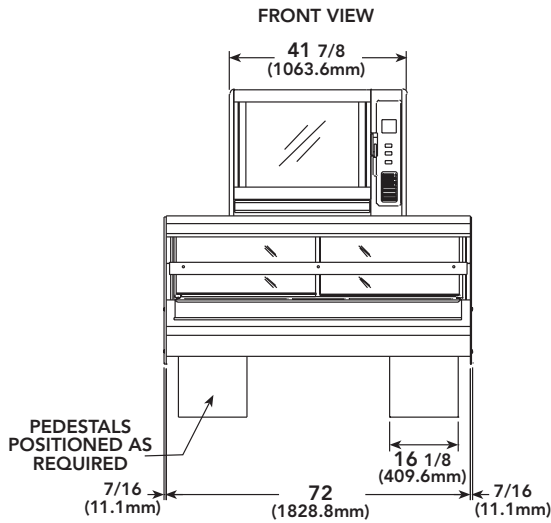

CASES HAVE VERTICAL ADJUSTMENT OF +1 1/2" (38.1mm)



**BKI Worldwide Headquarters**

P.O. Box 80400 Simpsonville, SC 29680-0400 USA • Tel: 864-963-3471 • Toll Free: 1-800-927-6887  
Sales Fax: 509-352-5350

**BKI Europe (U.K.)**

Tel: (44) 8950 8222

Fax: (44) 8956 0233

**BKI Latin America**

Tel: 954-442-0480

Fax: 954-442-0480





## ROTISSERIE/DELI CASE FEATURES

### Attention To Detail

BKI manufactures equipment with a high quality of precision engineering right down to installation. BKI's cases are equipped with leg levelers to assist operators in conveniently installing and incorporating BKI's deli cases into foodservice venue's.

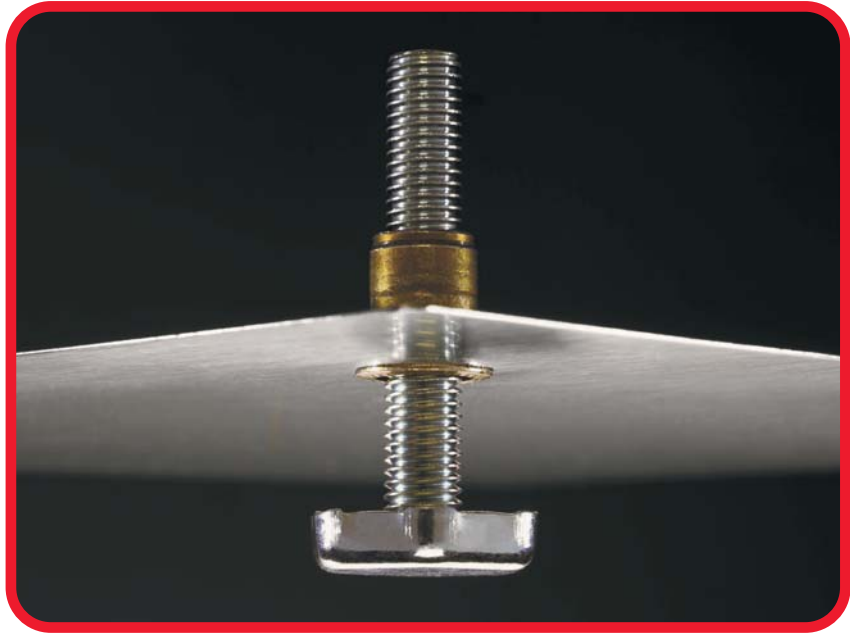

### Precision-Controlled Thermostats

BKI simplifies the operating process with an easy-to-use control panel for individual temperatures to expand merchandising capabilities.



### BKI Worldwide Headquarters

P.O. Box 80400 Simpsonville, SC 29680-0400 USA • Tel: 864-963-3471 • Toll Free: 1-800-927-6887  
Sales Fax: 509-352-5350

### BKI Europe (U.K.)

Tel: (44) 8950 8222

Fax: (44) 8956 0233

### BKI Latin America

Tel: 954-442-0480

Fax: 954-442-0480