

DRG-40 GAS-FIRED DOUBLE REVOLVING ROTISSERIE ■

Designed for theater, the DRG's attractive ambient flame combined with ample capacity - up to 48 chickens per hour - will heat up any supermarket's appeal and profitability.

Cook meats and vegetables to satisfy peak demand and enjoy the efficiencies gas delivers. The DRG offers innovative features including Cool Door technology, push-button water fill, easy to clean parts and an array of accessories that extend its versatility.



STANDARD FEATURES

- o Efficient Gas Operation
- o Large Capacity
- o Cool Door for Safety
- o Push Button Water Fill
- o Easy to Clean
- o Split Rotor System for Easy Cleaning
- o Ambient Flame with Ceramic Logs

OPTIONS FOR SPECIFICATION

- o LP or Natural Gas

ACCESSORIES

- o Meat Baskets (large and small)
- o Meat Forks
- o V-Spit
- o Insulated Mitt



Specifications subject to change without notice.



BKI North America

P.O. Box 80400 • Simpsonville, SC 29680
Tel: (864) 963-3471 • (800) 927-6887 • Fax: (864) 967-2787

BKI Europe

Tel: +(44) 01189 508222
Fax: +(44) 01189 560233

www.bkideas.com

DRG-40 GAS-FIRED DOUBLE REVOLVING ROTISSERIE

SPECIFICATIONS

DIMENSIONS

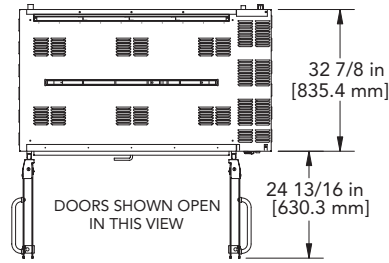

TOP VIEW

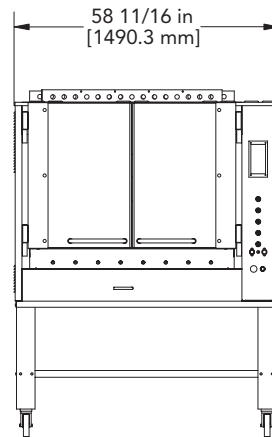

FRONT VIEW

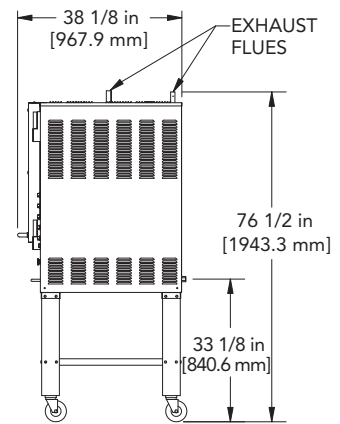

RIGHT SIDE VIEW

FLOOR SPACE

160.81 sq.ft. (14.94 m²)

CAPACITY

Meat Fork: 40-3lb. chickens
V-Spit: 32-3lb. chickens

HEATING FORMAT

Ceramic Infrared Burners

SHIPPING WEIGHT

1482 lbs. (672.2 kg)

ELECTRICAL

GAS SPECIFICATIONS

	BTU	Pressure min	max	Inlet
Natural	135,000/Hr	7" w.c.	14" w.c.	3/4"

ELECTRICAL SPECIFICATIONS

Volts	Amps	Breaker	KW	Phase
120	1.84	15	.22	1

© BKI LI0086 4-04 Specifications subject to change without notice.



BKI North America

P.O. Box 80400 • Simpsonville, SC 29680
Tel: (864) 963-3471 • (800) 927-6887 • Fax: (864) 967-2787

BKI Europe

Tel: +(44) 01189 508222
Fax: +(44) 01189 560233



www.bkideas.com