



FS

## COUNTERTOP ROTISSERIE

Tempered, thick safety glass door helps keep employees and customers safe



Programming is easy with a microprocessor control panel

Perfect for delis, convenience stores and quick-serve restaurants, BKI's countertop rotisserie utilizes valuable counter space with a 'hot-hold' feature to enhance product merchandising and profitability. Serve your customers self-basted chicken, buffalo wings, turkey breasts or ribs cooked perfectly time and time again with BKI's versatile rotisserie. Excellent lighting promotes eye appeal and helps maintain optimum temperature so your customers keep coming back for more.



FS

TOP VIEW

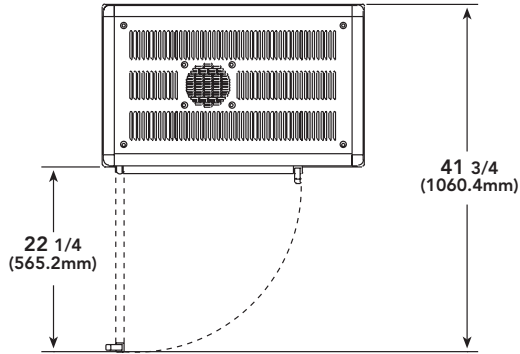

ELECTRICAL SPECIFICATIONS

Voltage	120	120/208	120/240
Phase	1	1	1
Wires	2	3	3
Amps	25	15	13
Breaker	35	30	20
kW	3	3	3

DIMENSIONS

Height	32 3/4" (831.8 mm)
Width	31 1/2" (800.1 mm)
Depth	19 1/2" (495.3 mm)
Floor Space	4.3 sq.ft (.39 m <sup>2</sup> )
Shipping Weight	195 lb. (88.5kg)
Shipping Cube	19.9 cu.ft (.56 m <sup>3</sup> )

FRONT VIEW

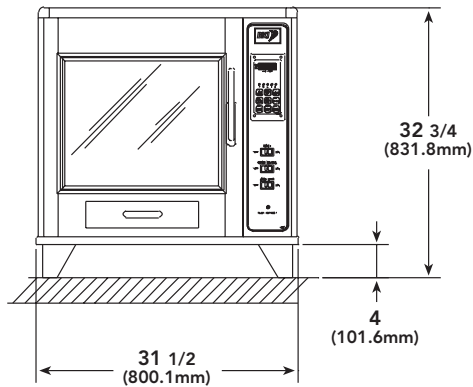

SIDE VIEW

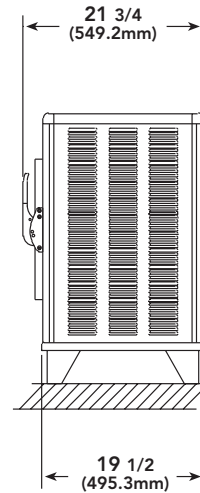

BKI Worldwide Headquarters

P.O. Box 80400 Simpsonville, SC 29680-0400 USA • Tel: 864-963-3471 • Toll Free: 1-800-927-6887  
Sales Fax: 509-352-5350

BKI Europe (U.K.)

Tel: (44) 8950 8222

Fax: (44) 8956 0233

BKI Latin America

Tel: 954-442-0480

Fax: 954-442-0480

