



MM-4

MOBILE MERCHANDISER

Customize your merchandisers by adding color to your display



Optional wooden accessories offer versatility and flexibility

Casters make merchandising anywhere in your store easy and hassle-free for extended mobility

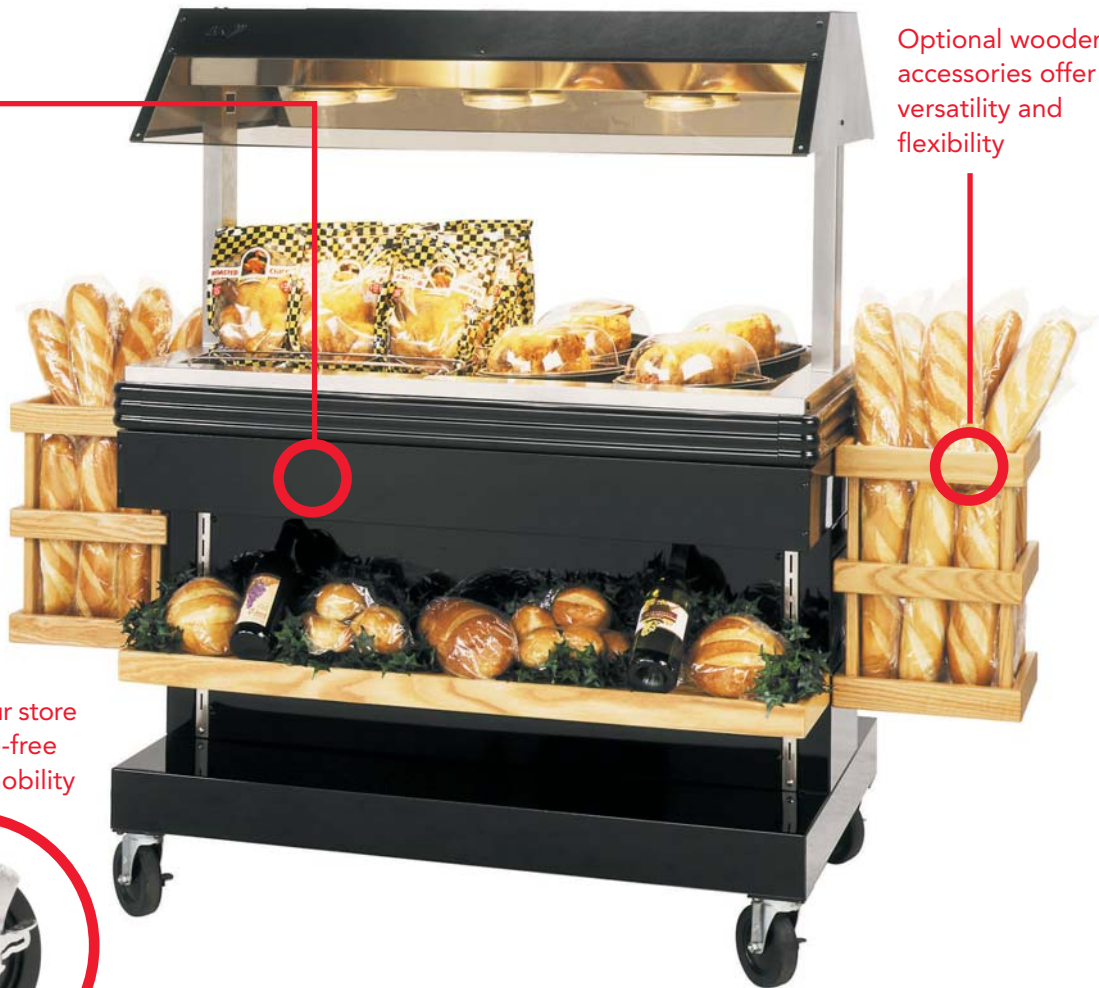

BKI offers you flexibility when displaying hot food items with our Mobile Merchandiser. Using waterless deli technology, BKI's merchandiser does not require plumbing and is powered by 120 volts, affording you limitless flexibility. Extend merchandising time and boost impulse sales with merchandisers that keep food hot and fresh for hours.



MM-4

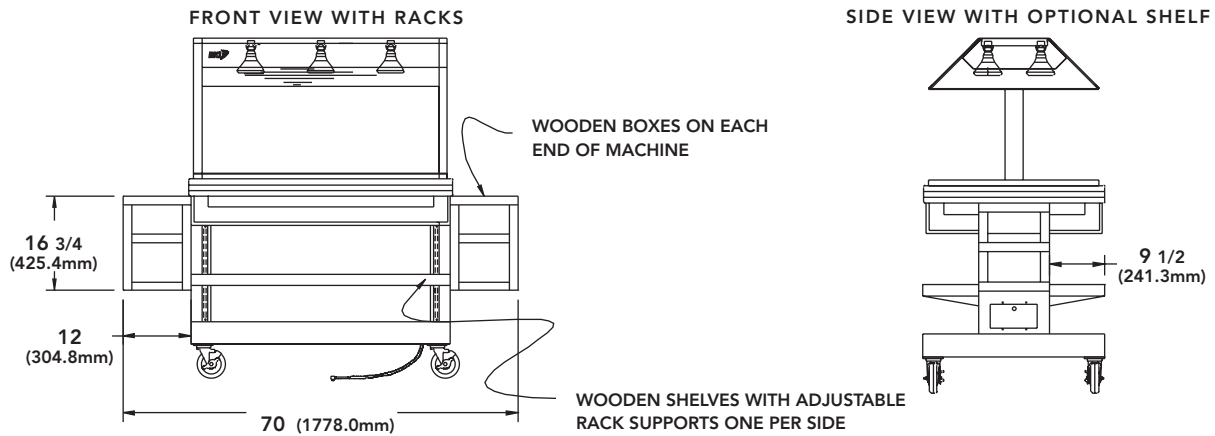
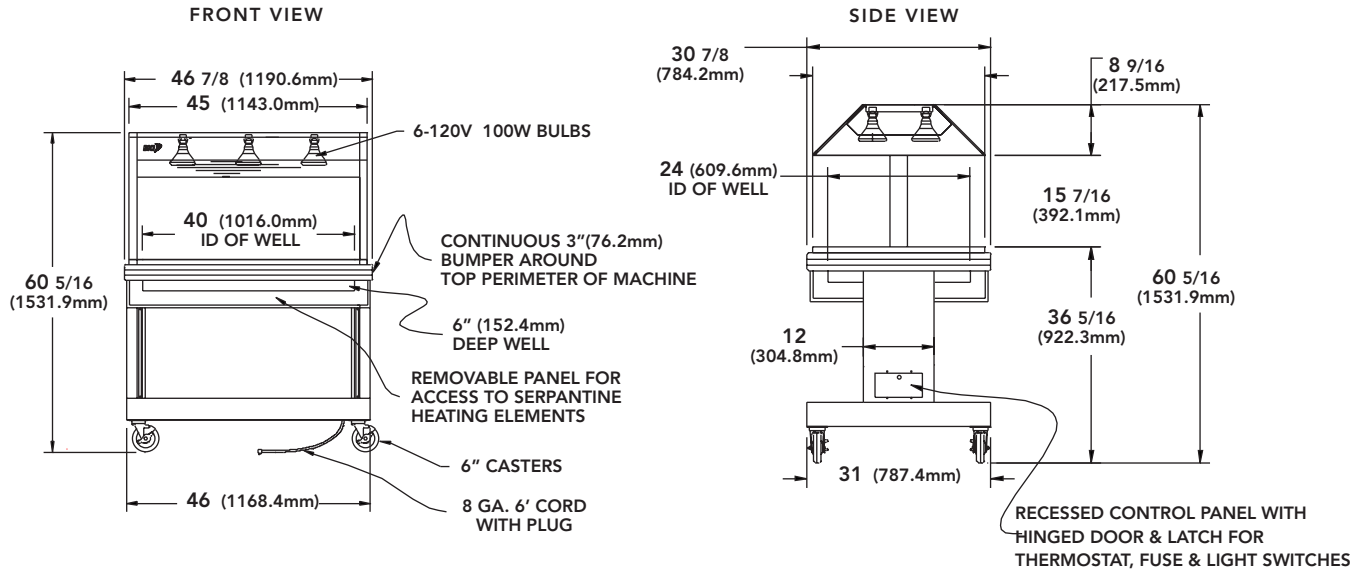

SHOWN WITH OPTIONAL RACKS AND SHELVES

ELECTRICAL SPECIFICATIONS

Voltage	120
Phase	1
Wires	2
Amps	15.0
Breaker	20
kW	1.8

DIMENSIONS

Height	60 5/16" (1531.9 mm)
Width	46 7/8" (1190.6 mm)
Depth	30 7/8" (784.2 mm)
Floor Space	9.6 sq.ft (.9 m ²)
Shipping Weight	435 lb. (197.3 kg)
Shipping Cube	93.4 cu.ft (2.6 m ³)

△ CHANGED BULBS TO 120V 100W FL0028



BKI Worldwide Headquarters

P.O. Box 80400 Simpsonville, SC 29680-0400 USA • Tel: 864-963-3471 • Toll Free: 1-800-927-6887
Sales Fax: 509-352-5350

BKI Europe (U.K.)

Tel: (44) 8950 8222
Fax: (44) 8956 0233

BKI Latin America

Tel: 954-442-0480
Fax: 954-442-0480

