



MM-6

MOBILE MERCHANDISER

Customize your merchandisers by adding color to your display



Double your display size with optional risers that allow packaged food to be stacked in one compact merchandiser

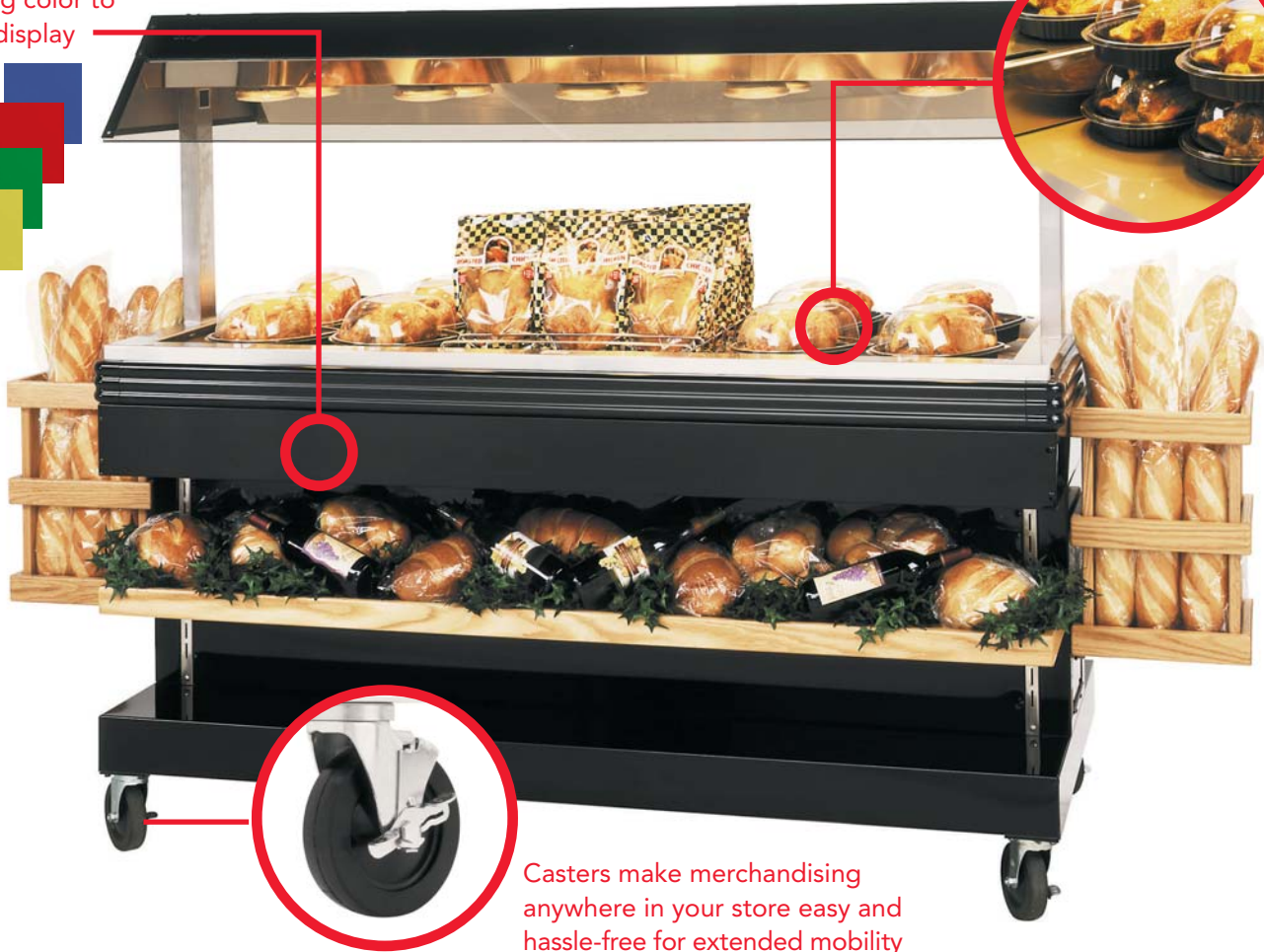

Casters make merchandising anywhere in your store easy and hassle-free for extended mobility

BKI offers you flexibility when displaying hot food items with our Mobile Merchandiser. Using waterless deli technology, BKI's merchandiser does not require plumbing, affording you limitless flexibility. Extend merchandising time and boost impulse sales with merchandisers that keep food hot and fresh for hours.

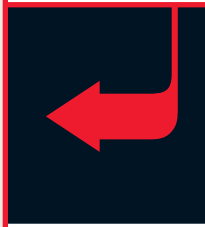

MM-6

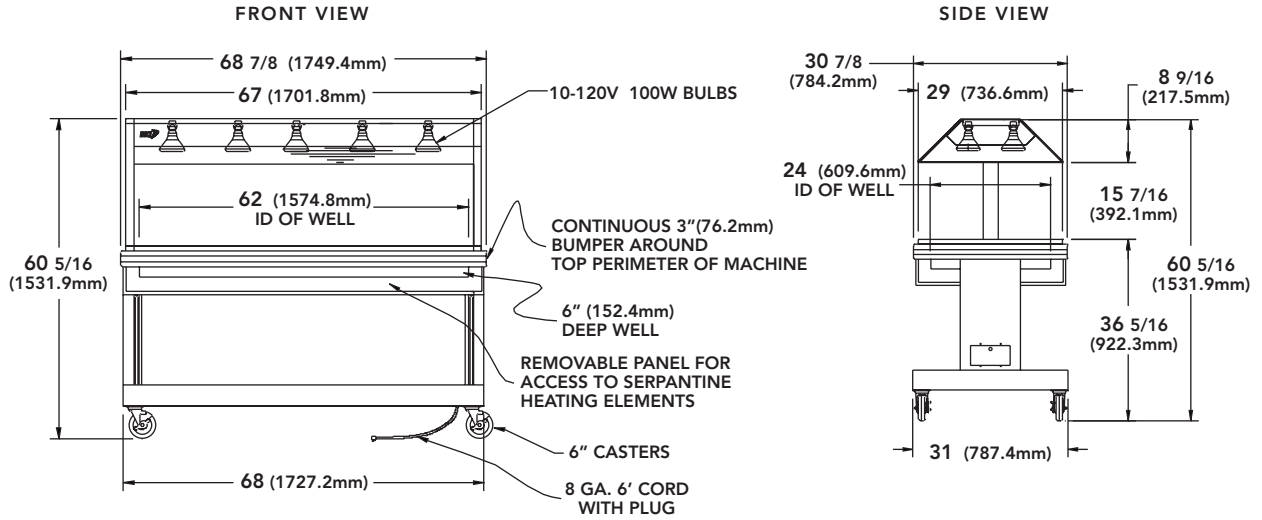

FRONT VIEW WITH RACKS

SIDE VIEW WITH OPTIONAL SHELF

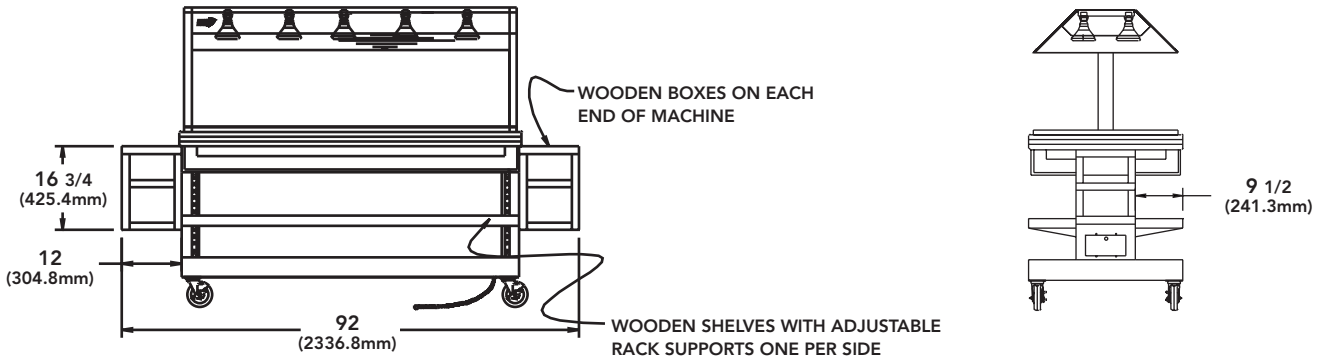

SHOWN WITH OPTIONAL RACKS AND SHELVES

ELECTRICAL SPECIFICATIONS

Voltage	120
Phase	1
Wires	2
Amps	25.0
Breaker	30
KW	3.0

DIMENSIONS

Height	60 5/16" (1531.9 mm)
Width	68 7/8" (1749.4 mm)
Depth	30 7/8" (784.2 mm)
Floor Space	13.5 sq.ft (1.4 m ²)
Shipping Weight	645 lb. (292.6 kg)
Shipping Cube	133.3 cu.ft (3.8 m ³)

△ CHANGED BULBS TO 120V 100W FL0028



BKI Worldwide Headquarters

P.O. Box 80400 Simpsonville, SC 29680-0400 USA • Tel: 864-963-3471 • Toll Free: 1-800-927-6887
Sales Fax: 509-352-5350

BKI Europe (U.K.)

Tel: (44) 8950 8222
Fax: (44) 8956 0233

BKI Latin America

Tel: 954-442-0480
Fax: 954-442-0480

