

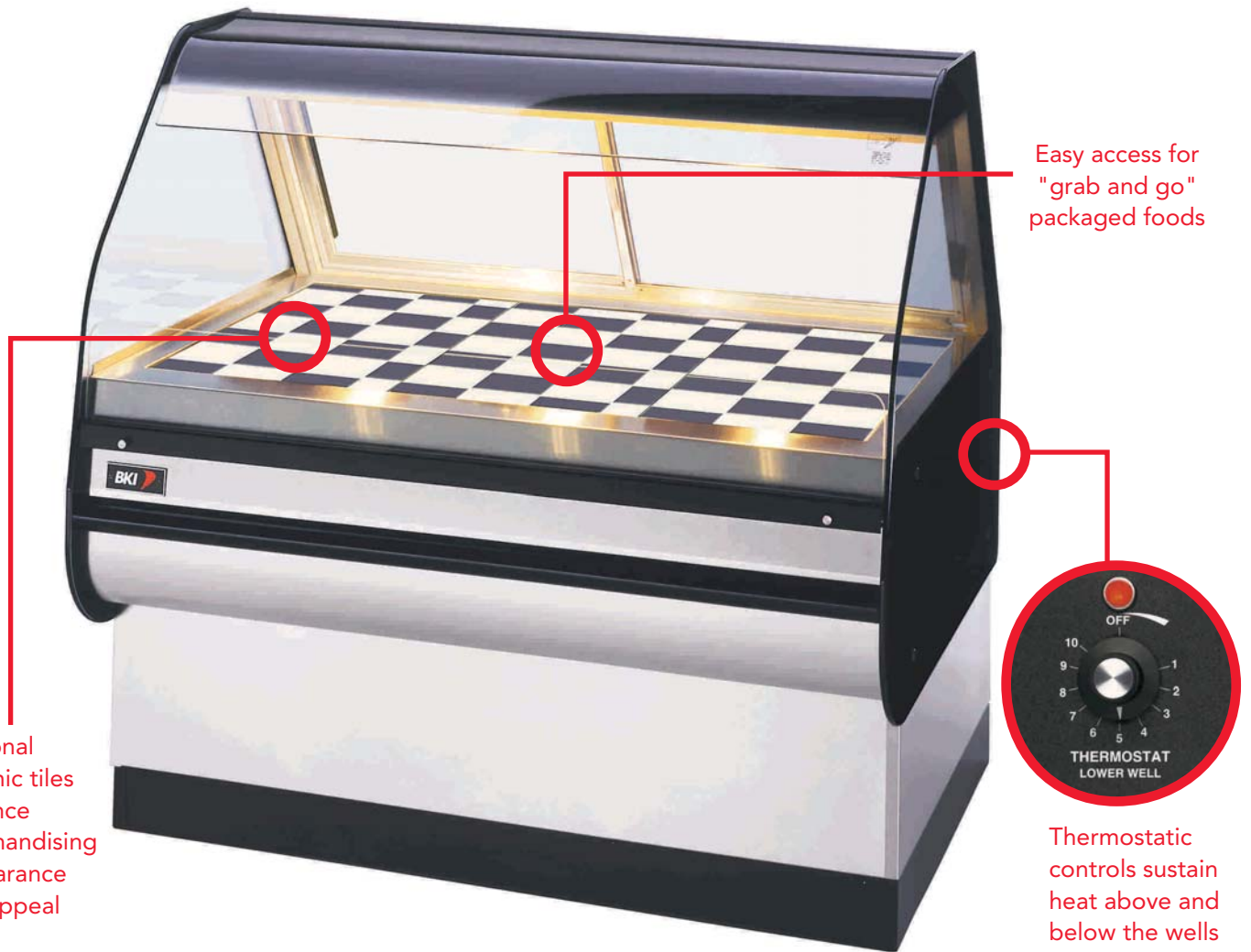

SSW-4

SURFACE WARMERS



Extend merchandising time and expand menu options with BKI's self-serve surface warmer. With a self-serve warmer, make dinner selection a convenient and easy decision for your customers. Precision-controlled temperature zones afford versatility for maximum even-heat distribution to keep foods fresh for hours.



SSW-4

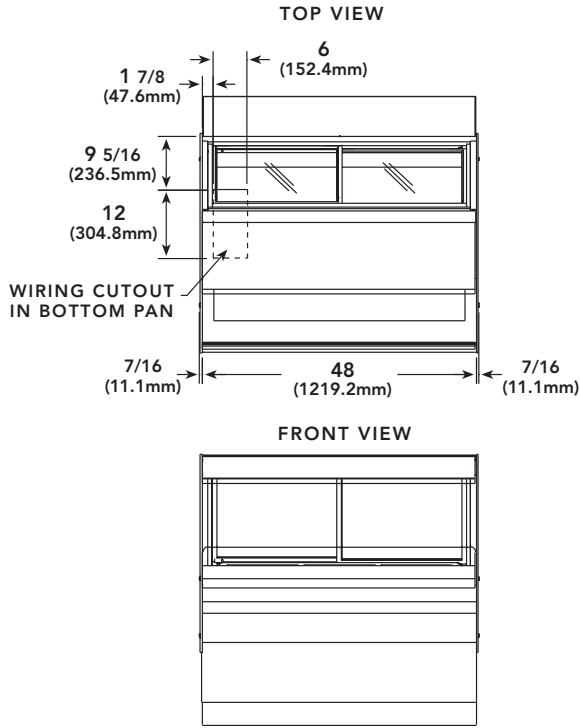

ELECTRICAL SPECIFICATIONS

Voltage	208	220	240
Phase	3/1	3/1	3/1
Wires	3/2	3/2	3/2
Amps	14.0/22.5	12.2/20.0	13.2/21.2
Breaker	20/30	20/30	20/30
kW	4.7	4.3	5.1

DIMENSIONS

Height	47 7/16" (1204.9 mm)
Length	48 7/8" (1241.4 mm)
Depth	38 3/8" (974.7 mm)
Floor Space	13 sq.ft (1.2 m ²)
Shipping Weight	560 lb. (254.0 kg)
Shipping Cube	94.5 cu.ft (2.7 m ³)

SSW-6

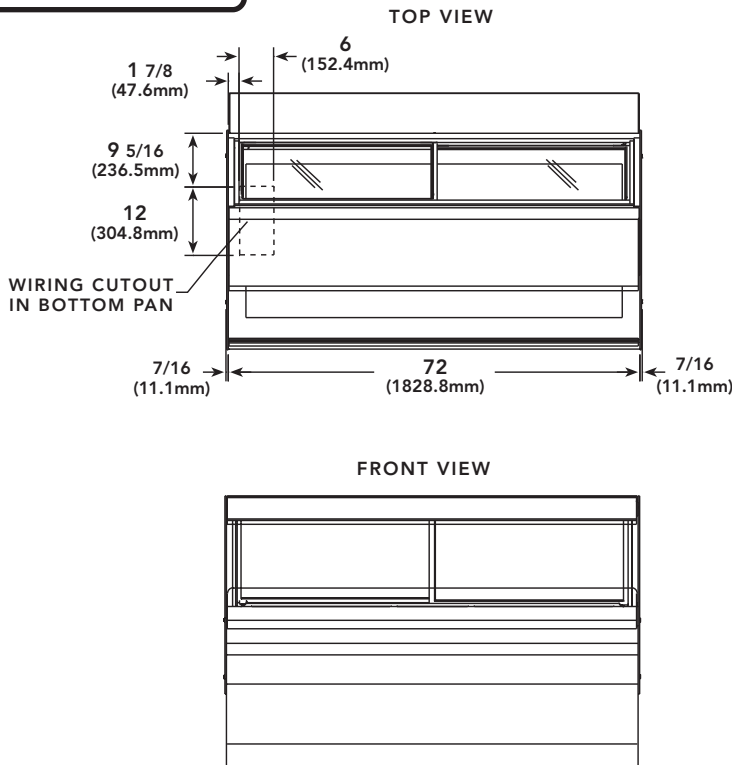

ELECTRICAL SPECIFICATIONS

Voltage	208	220	240
Phase	3/1	3/1	3/1
Wires	3/2	3/2	3/2
Amps	24.0/37.6	20.5/32.7	22.3/35.4
Breaker	30/50	30/45	30/45
kW	7.8	7.2	8.5

DIMENSIONS

Height	47 7/16" (1204.9 mm)
Length	72 7/8" (1851 mm)
Depth	38 3/8" (974.7 mm)
Floor Space	19.44 sq.ft (1.8 m ²)
Shipping Weight	695 lb. (315.3 kg)
Shipping Cube	134.5 cu.ft (3.8 m ³)

CASES HAVE VERTICAL ADJUSTMENT OF +1 1/2" (38.1mm)



BKI Worldwide Headquarters

P.O. Box 80400 Simpsonville, SC 29680-0400 USA • Tel: 864-963-3471 • Toll Free: 1-800-927-6887
Sales Fax: 509-352-5350

BKI Europe (U.K.)

Tel: (44) 8950 8222

Fax: (44) 8956 0233

BKI Latin America

Tel: 954-442-0480

Fax: 954-442-0480



SSW-8

TOP VIEW

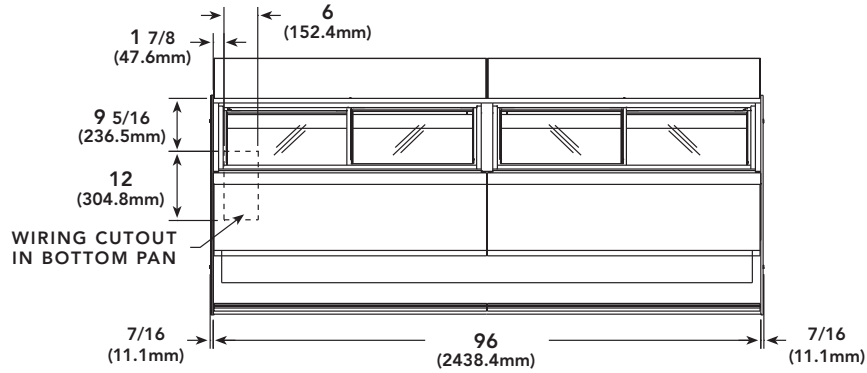

SIDE VIEW

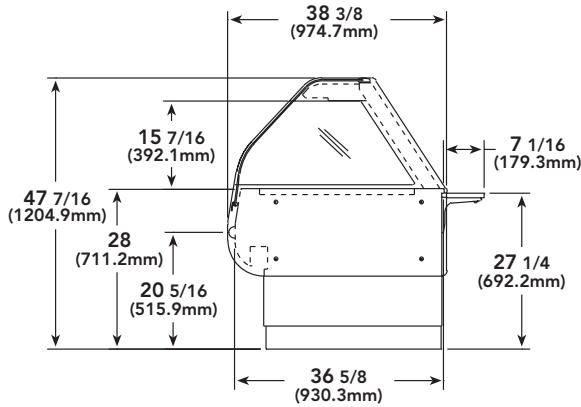

ELECTRICAL SPECIFICATIONS

	208	220	240
Voltage	208	220	240
Phase	3/1	3/1	3/1
Wires	3/2	3/2	3/2
Amps	33.6/43.3	29.4/42.7	31.7/46.2
Breaker	45/60	40/60	40/60
kW	10.9/9.0	10.1/9.4	11.9/11.1

DIMENSIONS

Height	47 7/16" (1204.9 mm)
Length	96 7/8" (2460.6 mm)
Depth	38 3/8" (974.7 mm)
Floor Space	25.81 sq.ft (2.4 m ²)
Shipping Weight	945 lb. (428.6 kg)
Shipping Cube	175.3 cu.ft (5.0 m ³)

FRONT VIEW

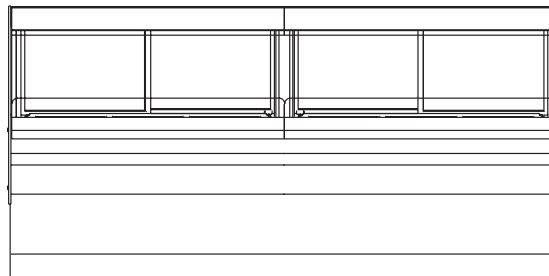

CASES HAVE VERTICAL ADJUSTMENT OF +1 1/2" (38.1mm)



BKI Worldwide Headquarters

P.O. Box 80400 Simpsonville, SC 29680-0400 USA • Tel: 864-963-3471 • Toll Free: 1-800-927-6887

Sales Fax: 509-352-5350

BKI Europe (U.K.)

Tel: (44) 8950 8222

Fax: (44) 8956 0233

BKI Latin America

Tel: 954-442-0480

Fax: 954-442-0480





Fresh ideas in foodservice equipment

www.bkideas.com

SURFACE WARMER FEATURES

Attention To Detail

BKI manufactures equipment with a high quality of precision engineering right down to installation. BKI's cases are equipped with leg levelers to assist operators in conveniently installing and incorporating BKI's deli cases into foodservice venue's.

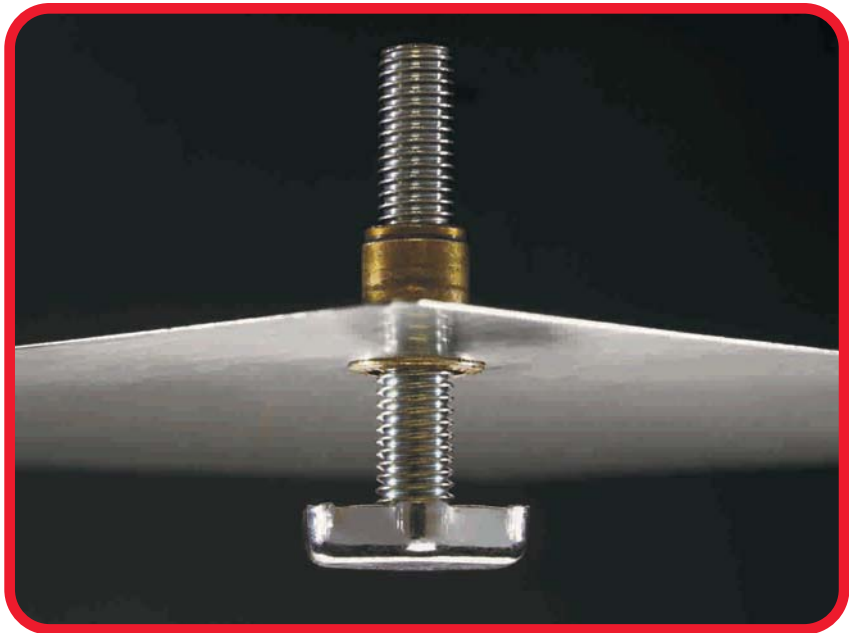

Precision-Controlled Waterless Wells

BKI simplifies the operating process with an easy-to-use operating panel that controls individual wells to expand merchandising.



BKI Worldwide Headquarters

P.O. Box 80400 Simpsonville, SC 29680-0400 USA • Tel: 864-963-3471 • Toll Free: 1-800-927-6887
Sales Fax: 509-352-5350

BKI Europe (U.K.)

Tel: (44) 8950 8222
Fax: (44) 8956 0233

BKI Latin America

Tel: 954-442-0480
Fax: 954-442-0480