

VG-16 ROTISSERIE ■

Ideal for supermarkets and superstores, the VG-16's high volume capacity cooks up to 80 x 1.35 kg chickens to perfection in 75 minutes to meet growing consumer demands and improve profitability.

Easy to assemble, superior servicing access and safety features including innovative cool-door technology save staff time and hassle. Plus, 15 custom programs can be stored to increase menu offerings from poultry to pork, beef, vegetables and pies and ensure uniform, consistent results every time.



STANDARD FEATURES

- o High capacity - up to 80 chickens
- o High visibility with attractive design
- o Lighted theatre for maximum customer attraction
- o Curved glass picture window
- o 15 program modes with pre-heat and holding capability
- o Cool-door design for safety
- o Removable stainless steel parts for ease of cleaning

OPTIONS FOR SPECIFICATION

- o Pass-thru or solid back
- o Flat or curved glass

ACCESSORIES

- o Meat forks
- o Meat baskets



Specifications subject to change without notice.



www.bkideas.com

BKI North America
P.O. Box 80400 • Simpsonville, SC 29680
Tel: (864) 963-3471 • (800) 927-6887 • Fax: (864) 967-2787
website: www.bkideas.com

BKI Europe
Tel: + 44 (0)870 9904242
Fax: + 44 (0)870 9904243

DIMENSIONS

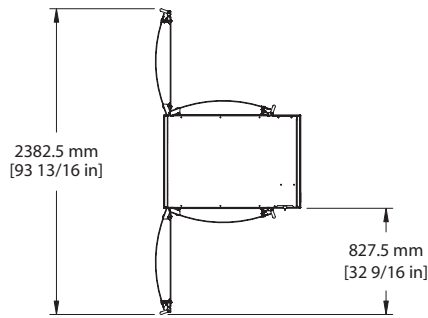

TOP VIEW

*VG-16 SHOWN IS EQUIPPED WITH OPTIONAL CURVED GLASS DOORS

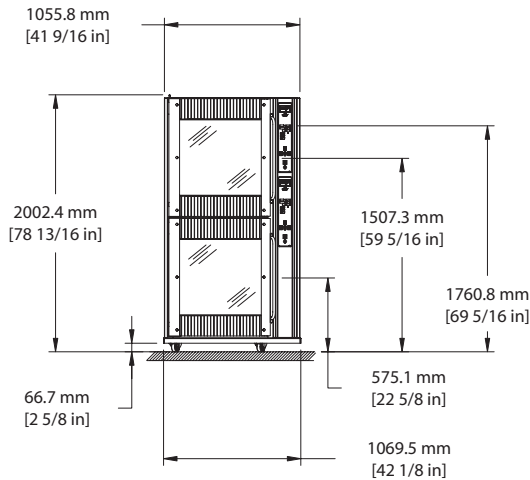

FRONT VIEW

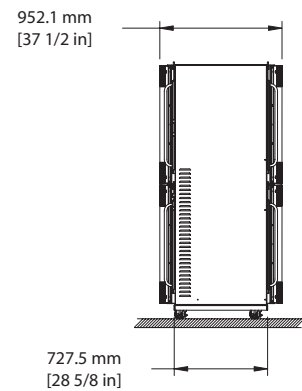

RIGHT SIDE VIEW

FLOOR SPACE

1.0 m² (10.8 sq.ft.)

CAPACITY

80 x 1.35 kg chickens

HEATING FORMAT

Convection

SHIPPING WEIGHT

408.2 kg (900 lbs.)

ELECTRICAL

ELECTRICAL SPECIFICATIONS (US)

Volts	Amps	Breaker	KW	Wires	Phase
208	35.7*	50*	12.6*	3	3
240	36*	50*	14.6*	3	3
220/380	38.5*	50*	12.4*	4	3
230/400	31.3*	40*	21.1*	4	3
240/415	32.6*	50*	22.8*	4	3

*Ratings per oven cavity - a separate power supply required for each oven cavity.